



# Calibration with bridge measurements

White Paper

By Dipl.-Ing Martin Riedel

Whoever is testing, expects their measurements to be precise and accurate. Thus, the value that is given by the measurement device must be consistent and close to the actual value. To ensure the accuracy and precision of a measurement device, it must be calibrated regularly. Without getting into the formal definitions and subtle differences between "balancing", "calibration" and "adjustment", the following can be distinguished:

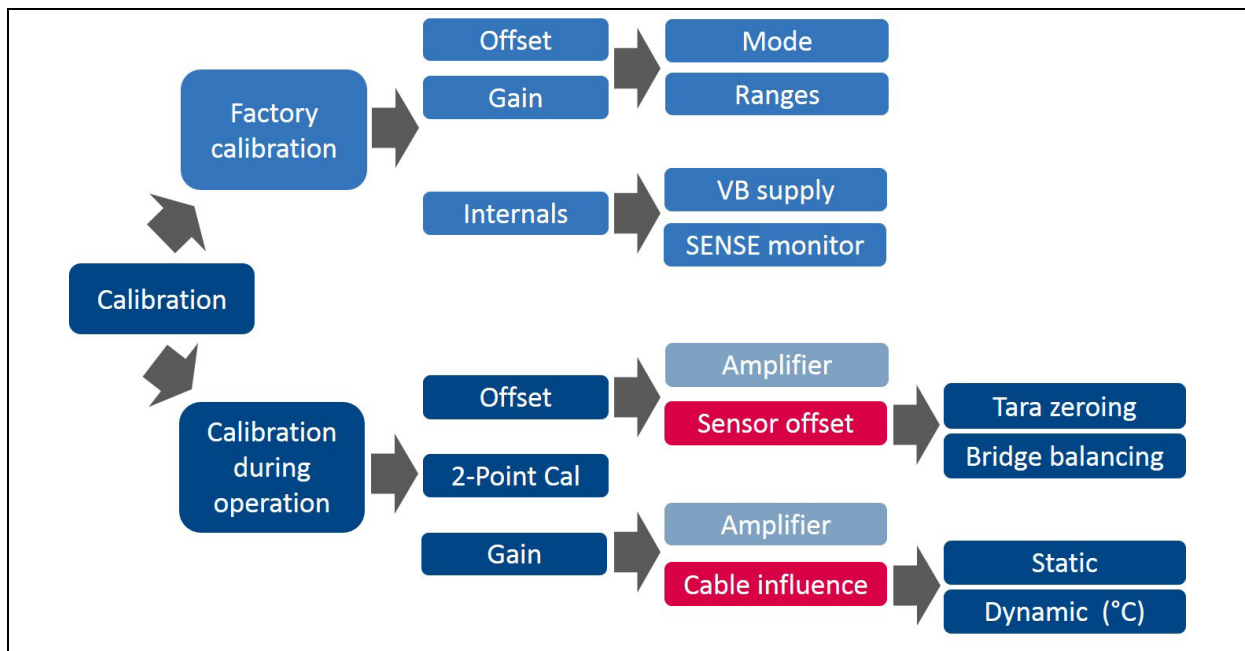

### **Calibration: Concepts and classifications**

### **Offset: Tara vs. Bridge balancing**

In contrast to the tare balance, which is used in the "simple" mode voltage, the bridge balance can compensate for the initial values which are greater than the selected nominal measurement range itself:

For bridge circuit leads, (opposite) deviations of the individual elements are caused: **+/- 0.1% to → 1 mV/V bridge offset**. During quarter-bridge completions, the appropriate precision for conventional strain gauges is generally reached with up to 0.3% production tolerance and with 3 mV/V offset: **easily a multiple of the selected measuring range!**

Because Tara zeroing makes a pure rescaling, this leads to different and asymmetrical measurement ranges. When used in bridge balancing, the actual range of the amplifier is greater than the actual measurement range. Using analog or digital compensation, the useful range is then shifted symmetrically about the new "virtual" zero point.

### Tara zeroing

- Formal rescaling, only
- Results in individually distinct and asymmetrical ranges (e.g., -11V ... +9V)

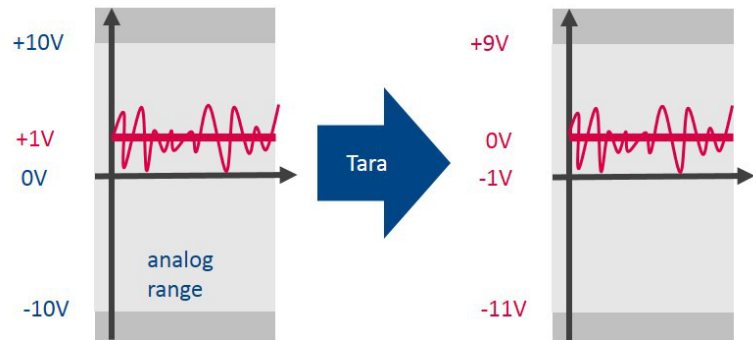

### Bridge balancing

- Offset can be much larger than active measurement range!
- Compensation and offset shifting
- Results in uniform and symmetric ranges (e.g., +/- 2mV/V)

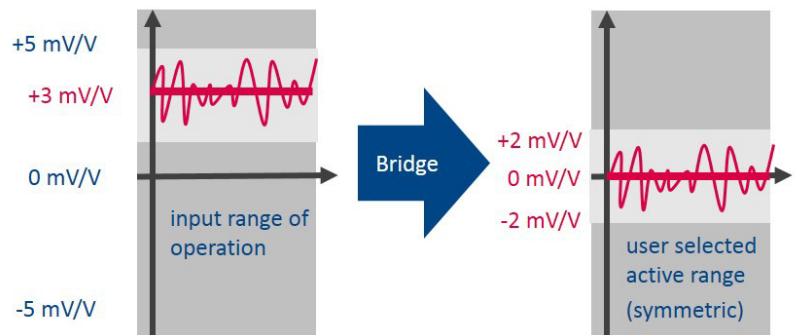

Modern digital concepts (such as imc systems) use high-resolution and stable 24-bit ADC, having enough headroom to digitize the entire offset signal, yet still providing sufficient resolution for the high-activity areas being used. Thus, the subtraction of the offset can be purely digital and realized absolutely drift-free.

## Digital bridge balancing

- Not depending on ultra-stable analog summing node – but based on stable ADC!
- Requires ADC to acquire the entire analog input range
- Advanced concept, enabled and driven by modern ADC technology with 24 Bit

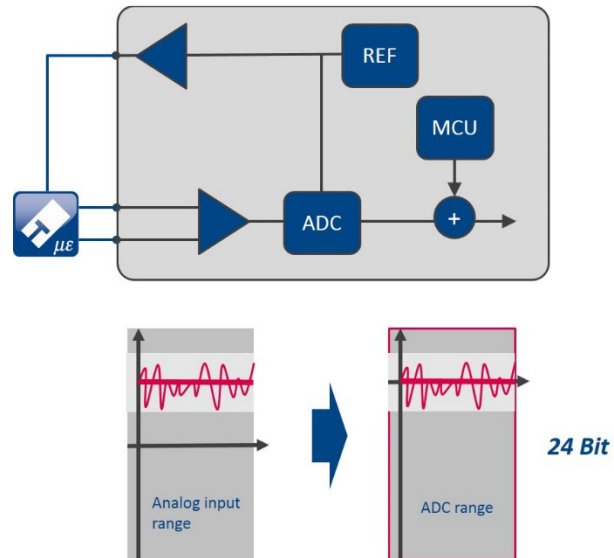

## Stability of zeroing/balancing

The fact that the bridge offset can take extremely large values, partly by the way, perhaps unexpectedly, that the stability of offset compensation with increasing initial offset is also determined by the gain drift of the system. It is namely subjected to the compensated value! E.g.,:

Initial Offset to be compensated: **2 mV/V @5V** according to **10 mV** absolute

Gain drift: **10 ppm / °C**

**Resulting equivalent offset drift:**  $10 \text{ mV} * 10 \text{ ppm} / \text{°C} = \mathbf{0.1 \mu V / \text{°C}}$

This is in the order of magnitude of a typical amplifier input stages as "direct" offset drift.

## Gain error due to cable resistance

Cable resistances in the supply lines cause an attenuation of the sensor actually effective excitation: After a power divider principle the ratio of bridge impedance to the sum of the cable resistance is crucial. This "loss" can be compensated by additional sensor leads (SENSE).

**E.g.,:** The Thinnest wire customary in sensor instrumentation: Copper size  $0.14 \text{ mm}^2$  (equivalent AWG26)

- **$0.14 \text{ mm}^2 == 130 \text{ m}\Omega / \text{m}$**
- **10 m** lead wire, feed and return lead  $\rightarrow$  double
- Worst case: low impedance bridge (120  $\Omega$  full-bridge  $\rightarrow$  European...)
- Typical:  $2 \times 1.3 \Omega / 120 \Omega \rightarrow$  approx. 2%

**10 m  $\rightarrow$  2 % Gain error**

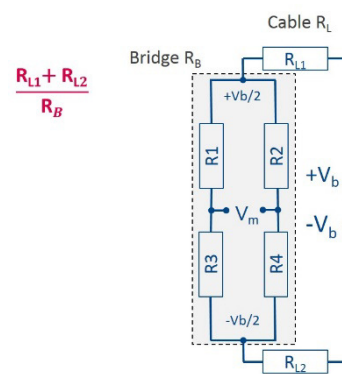

## Dynamic cable resistance from temperature drift

Should the unique compensation of the static gain error be performed at the beginning of the measurement, i.e., after installation, or must the correction be tracked during the running measurement operation? For outdoor test drive applications, temperature differences of 60 °C could occur, for instance, when the outside temperature in the morning at the start of measurement is -10 °C and by midday the temperature could be upwards of 50 °C.

The temperature coefficient of copper over 60°C leads to a resistance drift of:

- Cu: 4000 ppm/°C (“TK4000”)
  - $\Delta T$  = assumed 60°C operating range
  - 4000 ppm \* 60°C = 24 %
  - Thus, the initially matched gain error of 2% changes to :  
 $2\% * 24\% = 0.48\%$  **Gain drift** (10 m cable)
- For even longer cables, the it can be even more relevant:  
**4.8 % Gain drift** (100 m cable)

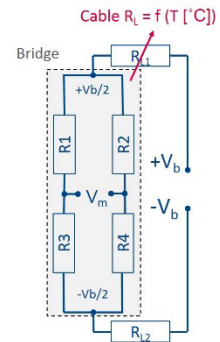

## Cable symmetry and simple sensor leads (SENSE)

Since Cables and wires are made from copper, they can be regarded almost always as a good "match"! Even for other cable types, significant local heating along the cable can still be considered “perfect.

Also contact resistances of connectors do not essentially disturb the symmetry: Typical values of a max. of 25 mΩ per contact lead, even when corroded, can be considered ideal:

$$\text{Mismatching and gain errors: } 25 \text{ m}\Omega / 120 \Omega = 0.02 \%$$

Thus: → **one single SENSE lead is sufficient!**

The compensation takes place in imc systems in a digitally:

The "basic" cable loss is detected by means of an additional measurement path and ADC, and mathematically compensated by twice the amount - and **continuously** during operation!

The dynamic compensation also acquires the temperature-induced drift of cable resistances.

In addition, even the undamped supply is directly acquired at the amplifier terminals VB to optimally compensate for even the residual tolerance.

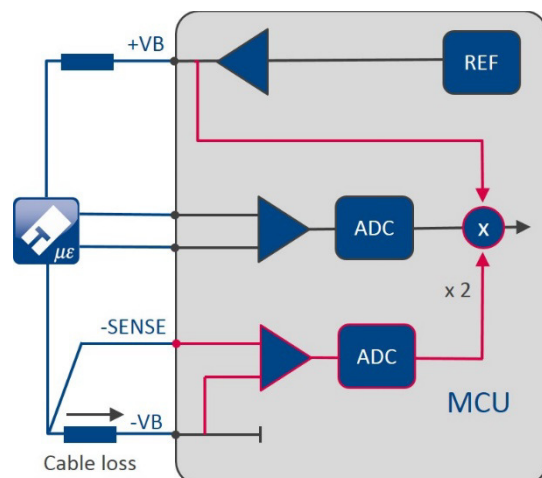

**Digital Single-SENSE compensation**

## Ratio-metric bridge measurements

In this way a perfect ratio-metric measurement bridge is achieved. Ratio-metric means that the bridge sensor in terms of "mV / V → mV signal pro V supply voltage" always delivers a fraction of the supply voltage. A damped supply can thus be compensated for by a purely computational gain correction. An actual "physical" adjustment of the voltage is to not even necessary. This avoids additional sources of error or stability problems of analog control loops.

## Double SENSE

So then are double-SENSE lines still necessary or even useful?

Apart from rare asymmetrical cases of cable resistances (see above), in particular carrier frequency modes, the double-SENSE phase relationships are accurately reached.

## Dynamic disturbance with half-bridge configuration

Advantageously, double-SENSE configurations can be used in more "exotic" cases where the likelihood of massive bad contacts or dynamic interference and couplings along the supply lines occur namely in half-bridge configuration. Why is this only for half-bridge configurations an issue?

When using a simple "single-SENSE", on the basis symmetry, the internal half-bridge completion is always connected to the internal +/- VB node.

Then unbalanced and dynamic disorders only affect the external (active) branch of the bridge, but not to the internal HB completion. While this still corresponds to insignificantly small gain errors, this can lead to observable offset errors or signal jumps.

Because these effects are dynamic in nature, they cannot be suppressed by (somewhat slower) arithmetic compensation.

Double-SENSE allows for symmetric +/-SENSE signal feedback and drives internal HB completion - Perfect for dynamic (analog) noise cancellation!

### Dynamic disturbance with half-bridge configuration:

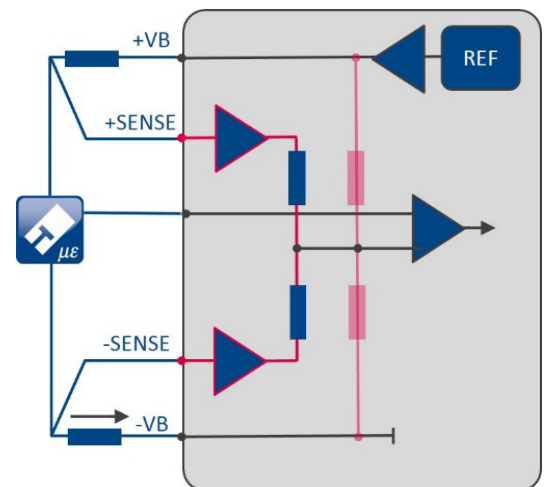

Dynamic noise injection or bad contacts on +/- VB

## Conclusion: SENSE with imc bridge amplifiers

- imc systems are generally equipped with SENSE line support
- Sense lead detects the actual effective supply voltage at the remote sensor
- Sense can be implemented with single or double wires:
  - Supply cables are symmetric: -> double Sense is usually not necessary
  - Economic single-SENSE is an important selling point for imc-modules
  - Double SENSE for CF and exotic cases of dynamic disturbances
  - The imc amplifier modules BR2-4 and UNI-4 offer both single and double SENSE:  
The software automatically detects the current wired configuration
- Arithmetic compensation of gain error - automatically in the background
- Dynamic adaptive compensation during active measurements even comprises thermal drift

## Quarter-bridge configuration

In quarter-bridge configuration, both the passive half-bridge completion and the lower quarter-bridge completion are completed in the amplifier. The strain gauge as the actual fourth element is connected with two or three (longer and resistance-afflicted) lines.

Next, half of the completed "primitive" 2-wire quarter-bridge circuit is presented. This is not really of practical importance since it has dramatic offset and drift problems, as shown in the following example:

### 2-wire

- Both cable resistances are associated with upper branch of the bridge
- **Cable-resistance** e.g.,  $2 * 10 \text{ m}, 130 \text{ m}\Omega / \text{m} = 2.6 \Omega$
- **Gain-error:**  $2.6 \Omega / 120 \Omega = 2\% \rightarrow \text{moderate}$
- **Offset-error:**

$$\frac{1}{4} * R_K / R_B = \frac{1}{4} * 2\%$$

$$\frac{1}{4} * 20 \text{ mV/V} = 5 \text{ mV/V} \rightarrow \text{dramatic!}$$
- **Offset-drift:** with Cu-Drift  $4000 \text{ ppm} / ^\circ\text{C} * 5 \text{ mV/V}$   

$$= 20 \mu\text{V/V} / ^\circ\text{C} \rightarrow \text{FATAL!!}$$

- This literally presents a thermometer:  
 50°C "control" already crosses the 1 mV/V range!!  
 $50 \text{ }^\circ\text{C} * 20 \mu\text{V/V} / ^\circ\text{C} = 1 \text{ mV/V}$

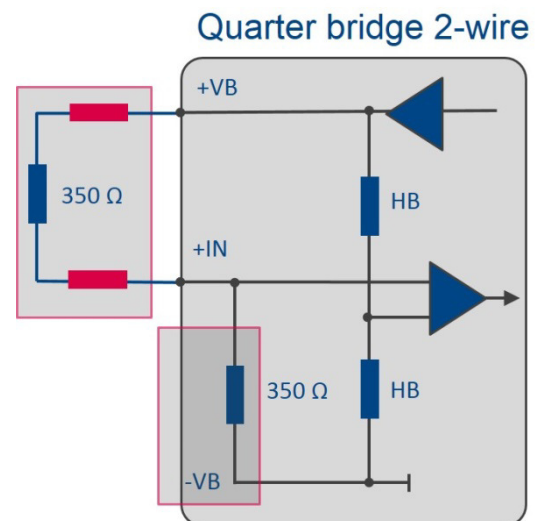

In contrast, almost exclusively used 3-wire circuits avoid this offset error due to the symmetrical distribution of the two cable portions on upper and lower bridge arms:

### 3-wire

- wires equally distributed: upper/lower branch
- **Offset** and Thermal drift: → **compensated**
- **Gain**-error: e.g., (10m)  $2.6 \Omega / 120 \Omega = 2 \%$   
→ **moderate and "initially" uncompensated**

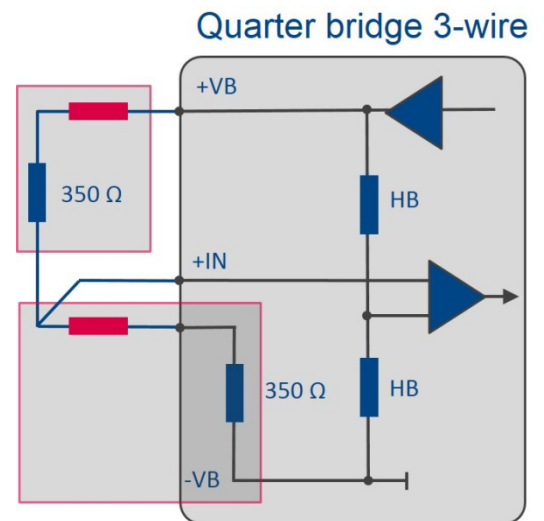

For "conventional" bridge amplifier or relevant competitors, where:

The remaining "moderate" gain error, determined by the ratio of cable resistance to bridge impedance, initially remains, when the "simple" 3-wire circuit is not taken into account, uncompensated!

It can typically be corrected by methods such as the "shunt calibration" and, in particular, on the internal quarter-bridge completion.

### ***imc 3-wire quarter-bridge completion (with gain compensation)***

While the offset stability of the 3-wire circuit are common property and state of the art, offer imc systems as an additional unique feature full gain correction for 3-wire circuit. ***imc systems additionally offer a unique full gain correction for a 3-wire circuit.***

In addition, a separate auxiliary amplifier with ADC is used to acquire the voltage drop along the "average" return conductor. Since this represents half of the total power loss, it is doubled and used for the computational gain correction.



**Conclusion:**

Thus, this dynamic tracking compensation makes any shunt calibration at quarter-bridge unnecessary and therefore superior.

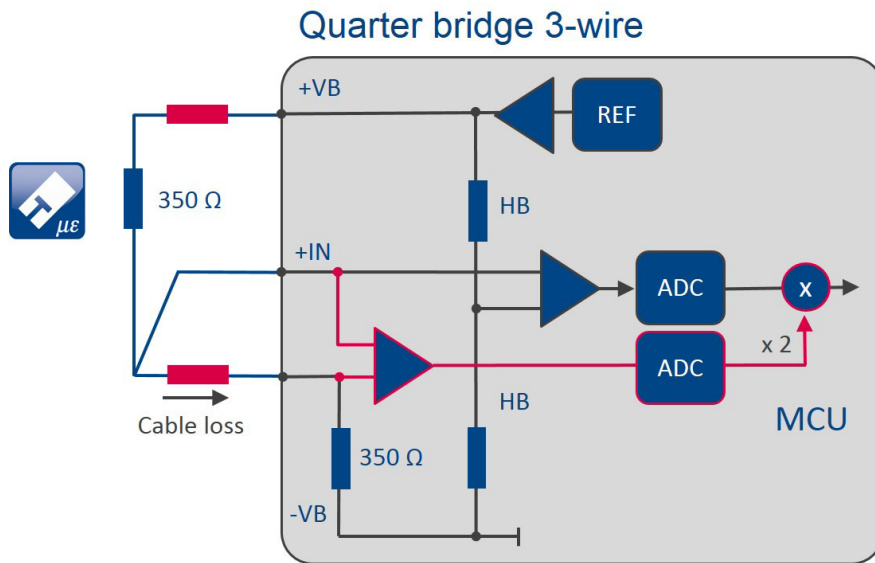

***imc 3-wire quarter-bridge circuit with dynamic gain correction***

***Shunt-calibration***

But if, as has been shown here, gain error through SENSE leads (Full- and Half-Bridge) and (especially with imc systems) and are also fully for the quarter-bridge dynamically acquired and compensated for, including external influences, then why is Shunt calibration necessary?!

In essence, the Shunt-calibration can provoke a change from, e.g., 0.5 mV/V, essentially to check the measurement chain qualitatively to ensure that no cable breaks or faulty wiring exists.

If one wanted to correct the device by checking the "internal factors", that is, check or further improve the factory calibration of the amplifier modules (which, for example, are calibrated at imc to typ. 0.02%), one would need the high-impedance calibration resistors to be accurate, even with what is quickly lost due to leakage resistances in the GΩ. It is clear that this is not necessary or can even be counter-productive.

The case remains in applications with such sensor installations (e.g., from an economic standpoint) that by using SENSE-cables, even the cable resistance influences will be corrected. As shown below, even more serious effects of cable resistances can be observed at the measurement input. These effects actually require a separate supply for the shunt resistance – that does not want or can afford, but in this case is needed...an apparent dilemma, however a clever solution exists with a new feature by imc!

In what way cable resistances falsify the shunt calibration? In *several* ways:

The parallel connection of a shunt directly to the strain gauge provokes a real signal change that is **smaller** than is expected;

Because of the attenuation of the power at the remote sensor, this causes **cable resistance at +/- VB**.

Magnitude: about  $\frac{R_{\text{cable}}}{R_{\text{strain gauge}}}$   
 (e.g.,: circa. 1% at  $1.3 \Omega / 120 \Omega$ )

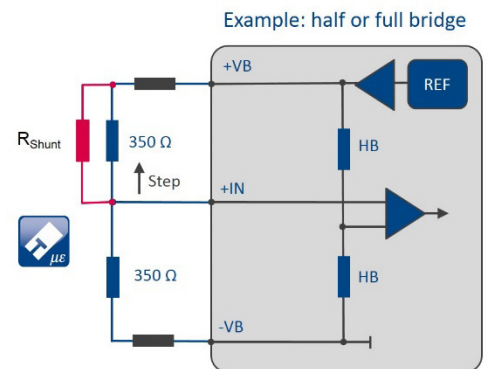

However, since the shunt is not locally connected at the remote sensor, but instead is connected internally in the amplifier, the shunt is parallel to the sum of the strain gauges and cables.

The ratio of "Bridge to shunt" is thus greater than nominal. Thus, the real jump is not small, but **larger**.

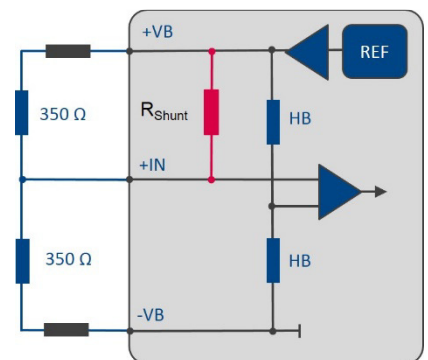

Another, more and opposite distortion however, is caused by the **cable resistance at the measuring input IN +**.

As an example, the 0.5 mV / V jump is achieved with 60 K $\Omega$  (analogous to the quarter-bridge jump =  $1/4 * \text{bridge/shunt}$ )

While on the other hand, the ratio is cable / shunt  $1.3 \Omega$  to 60 K $\Omega$ , thus only 22 ppm. But this voltage divider acts with half-bridge voltage:

$$VB/2 * 22\text{ppm} = 11\mu\text{V}/\text{V}$$

So instead of the expected attenuation, a further enlargement of the expected: 0.5mV / V jump by about 2.2%

This could be avoided by a separate supply for the calibration resistor. However, in general, this additional line is not available!

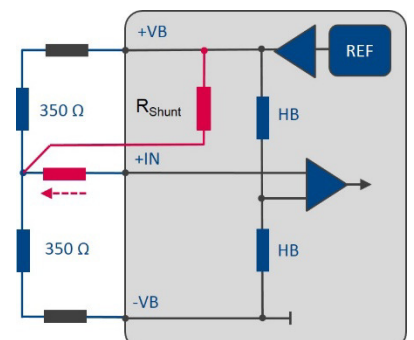
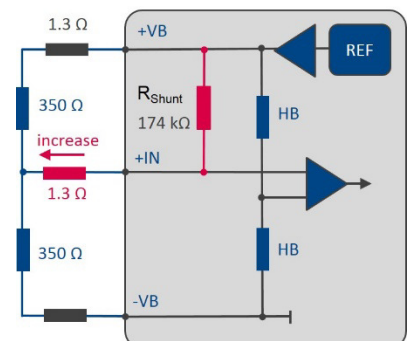

### Cable compensation without SENSE – via shunt calibration

Summing up these connections together in a mathematical model, which (rightly) assumes symmetrical cables, one can therefore (without additional lines!) calculate the cable resistance and thus the necessary gain correction from the distortion of calibration jump.

This function, among others, is a corresponding, automatic two-point calibration and is another exclusive and unique feature of imc amplifiers!

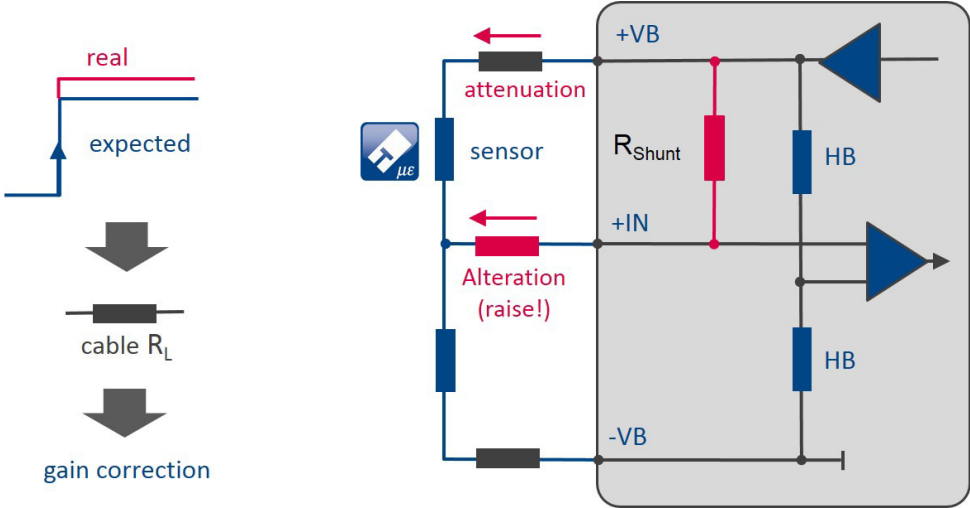

Cable compensation without SENSE – via shunt calibration

## Additional information:

### imc Test & Measurement GmbH

Voltastr. 5  
13355 Berlin, Germany

Telephone: +49 (0)30-46 7090-0  
Fax: +49 (0)30-46 31 576  
E-mail: [hotline@imc-tm.de](mailto:hotline@imc-tm.de)  
Internet: <http://www.imc-tm.com>

imc Test & Measurement GmbH is a manufacturer and solution provider of productive test and measurement systems. imc implements metrological solutions for research, development, service and production. imc has particular expertise in the design and production of turnkey electric motor test benches. Precisely outfitted sensor and telemetry systems complement our customer applications.

Our customers from the fields of automotive engineering, mechanical engineering, railway, aerospace and energy use imc measurement devices, software solutions and test stands to validate prototypes, optimize products, monitor processes and gain insights from measurement data. As a solution

provider, imc offers their customers an attractive and comprehensive range of services. These include project consulting, contracted measurements, data evaluation, specialist deployment, customer-specific software development and system integration. imc consistently pursues its claim of providing services for “productive testing”.

If you would like to find out more specific information about imc products or services in your particular location, or if you are interested in becoming an imc distributor yourself, please go to our website where you will find both a world-wide distributor list and more details about becoming an imc distributor yourself:

<http://www.imc-tm.com/our-partners/>



### Terms of use:

This document is copyrighted. All rights are reserved. Without permission, the document may not be edited, modified or altered in any way. Publishing and reproducing this document is expressly permitted. If published, we ask that the name of the company and a link to the homepage [www.imc-tm.com](http://www.imc-tm.com) are included. Despite careful preparation of the content, this document may contain errors. Should you notice any incorrect information, we kindly ask that you please inform us at [marketing@imc-tm.de](mailto:marketing@imc-tm.de). Liability for the accuracy of the information is excluded.